

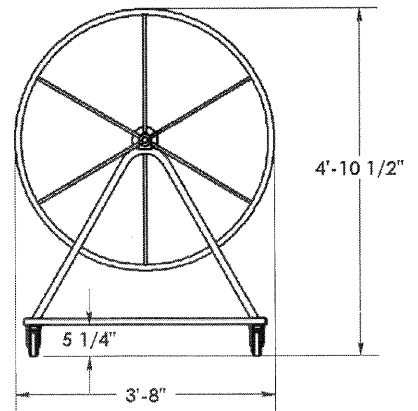

# Lane Line Storage Reel Model - Sheridan

Voice: 800-667-0677, Fax: 800-663-6338, E-Mail: [dizard@dizard.com](mailto:dizard@dizard.com)

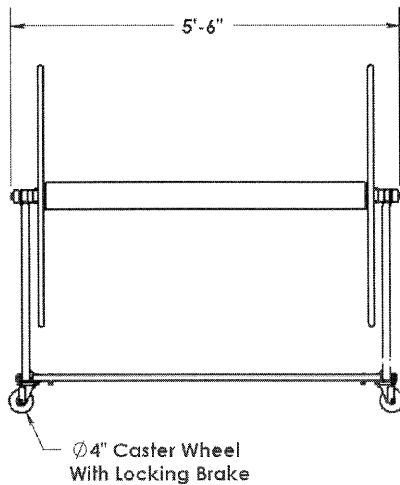
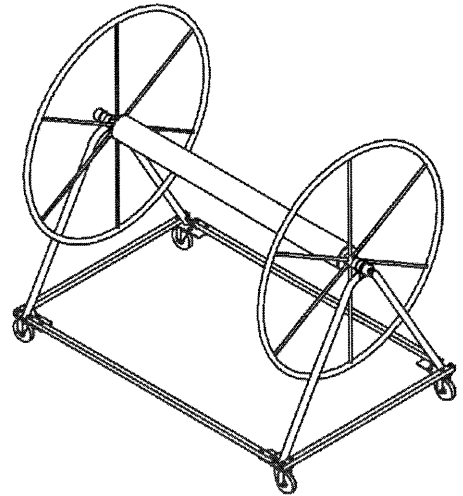
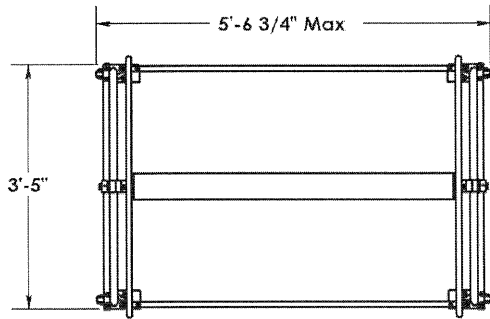

\*Note: Drawings not to scale. Specifications are nominal and are subject to change.

## **Specifications:**

The storage reel shall be the standard catalogued product of a company regularly engaged in the manufacture of such equipment. Alternate models of storage reels will not be considered unless equal to the specified product in every respect and must be submitted for approval not less than ten (10) calendar days prior to bid due date. Submittal data must include complete documentation relating to all the specified features and include manufacturer's sales literature, specification sheets, installation/operation/ maintenance manuals and engineering drawings.

## **Storage Capacity**

The storage reel shall be designed to accommodate either 4-inch or 6-inch diameter lane lines. The unit shall have a capacity of 375-feet of 4-inch diameter lane lines or 250-feet of 6-inch diameter lane lines. It shall be provided with four (4) 4-inch zinc castor wheels with locking brakes.

## **Material**

The storage reel end frames shall be constructed from 1.25-inch x .065-inch wall thickness 304-stainless steel. Horizontal connection tubes shall be 1-inch square tube x .065-inch wall thickness.

The storage reel shall be provided with two (2) 44-inch diameter-winding wheels constructed of 1.00-inch x .083-wall thickness stainless steel with 0.5-inch diameter 304-stainless steel rod spokes.

## **Finish**

All metallic components shall be twice passivated, incorporating both mineral and organic acid passivation techniques, for maximum corrosion resistance. Finish surface shall be a number 7 finish.

## **Warranty**

The reel assembly shall be covered by a two-year warranty.